

KYEC® Safety Power Rails

Application of Crane · Hoist · Warehouse · Kinds of Assemble Line

Appointed
Mark
KYEC

ISO 9001
Certificated
Since Year
2000



Index	Introduction	P1	3P-6P installment diagram	
	Choose suitable type and ampere	P2	I type safety power rail design	P14
	3P-6P safety power rail design	P3	I type safety power rail parts diagram	P15
	3P-6P parts diagram	P4	I type safety power rail installment diagram	P17
	High temperature durable box safety power rail	P10	Our performance sample	end cover

Introduction :

Being specialized in hoist repair and related innovation, KYEC provide our customers with excellent service based persistent devotion, responsibility and advanced technology.

In order to overcome the difficulties that we have been confronted with part importing, we dedicate ourselves to the production and innovation of parts and components. Also we have obtained numerous patents approved by R.O.C (Taiwan) and overseas countries.

KYEC supply our customers with readily available engineering materials and technical assistance to shorten time of preparation.

Safety power rails

The safety power rails are electrical conductors of various profiles that are used to provide electrical potential to moving systems along a path of travel which have 3-6 poles.

The safety power rails are available for a current load from 60A up to 200A mobile electrification technology for moving transportation vehicles and equipment. Common application include: manufacturing robots, material handling systems, hoist and cranes, automated storage facilities and retrieval systems.

Safety power rail systems are available in a variety of configuration depending on applications requirements. Enclosed conductor systems typically enclosed conductors in a protective conduit meeting safety standard.



General technical information

Conversion Table of Horse Power

Full Load Current Table of 3 Phase Alternating

H.P.	110V	220V	440V	500V	2300V
1/2	4	2	1	0.8	
3/4	5.5	2.8	1.4	1.1	
1	7	3.5	1.8	1.4	
1 1/2	10	5	2.5	2.0	
2	13	6.5	3.3	2.8	
3		9	4.5	4	
5		13	7.5	6	
7 1/2		22	11	9	
10		27	14	11	
15		33	22	16	
20		42	28	21	
25		54	37	28	7
30		78	39	31	8.5
40		104	52	41	10.5
50		128	63	50	13
60		150	75	60	16
75		180	93	74	19
100		246	125	98	25
125		310	166	124	31
150		360	180	144	37
200		480	240	192	46

Check the steps below first to select the correct current (Amperes) of safety power rails and current collector :

1. Calculate the total motor's Horse Power(H.P) required (ex.10H.P)
2. Make sure the rated voltage(V) is (ex.220V)
3. Get the current data by checking the above conversion table (ex.27 Amperes)

Safety Current Table of ConductorWire Assembling

The safety current of safety power rails would perhaps be affected if the circuit temperature is over 35°C.

Copper Conductor Wire			60°C Insulator	70°C Insulator	80°C Insulator	90°C Insulator
Category of Conductor Wire	Dimension mm ²	No. of Wire/Cable size	Amperes Capacity(A)			
Single Wire		1.6	25			
		2.0	36			
		2.6	45			
Shield Wire	2.0	70.8	25			
	3.5	70.8	25			
	5.5	71.0	45			
	6	71.2	55	65	70	80
	7.4	71.6	80	95	130	110
	22	72.0	100	125	125	140
	35	72.3	125	150	190	170
	38	72.4	145	180	190	205
	90	181.5	175	210	230	245
	85	182.0	200	240	280	280
	80	182.5	230	285	305	330
	100	182.6	270	330	350	38
	125	182.9	310	380	430	440
	150	179.5	360	440	480	505
	200	173.6	425	520	580	600
	250	812.3	505	615	680	710
	325	812.6	590	720	780	830
400	812.9	680	825	870	955	
500	812.2	795	930	985	1085	

Horse power =total kws/0.75; A = Horse Power/3; (on the assumption 220V)

Total current [A.] x1.25=proper current

According to the amperes quantity, choose the type of safety power rail:

90A -200A: 3-6P safety power rail

150A: 1 type safety power rail

120A 320A 500A 800A: W type safety power rail

Vertical design

- 3P for 3 phase on R.S.T
- 4P for 3 phase on R.S.T and one ground wire
- 5p for 3 phase on R.S.T and two control line
- 6P for 3 phase on R.S.T and three line for saddle motor

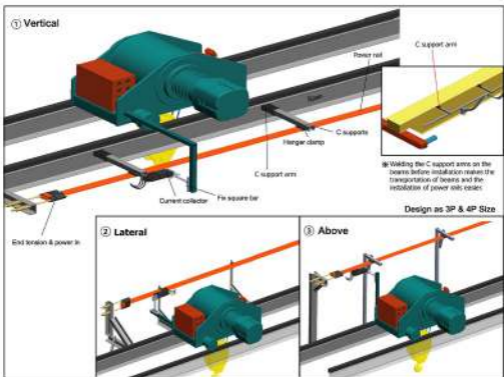
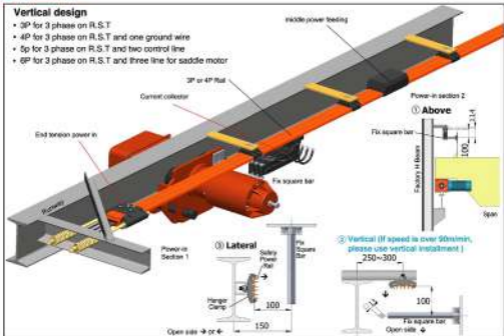

3P Safety power rail

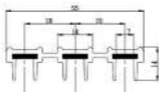

DFC 2N(99.9% good conductivity)

3P (Phase) Safety Power Rail				
Type	Capacity (A)	Thickness (mm)	Width (mm)	Weight (kg/m)
KY-AN3007	75	2	18	0.8
KY-AN3010	100	2.8	18	1.01
KY-AN3015	150	3	18	1.14

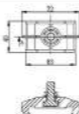

Use with C Track Support and C Plate M10 Nut 30 X 20 X 5'



KY-AN3100
3P Hanger Clamp

0.075 kg / pc

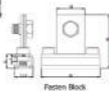
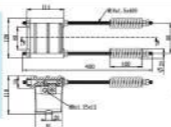

KY-AN3200
3P End Tension & Power in

1.73 kg / pc

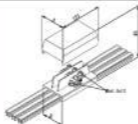

Type	Size	A	B
3P	70	62	
4P	90	82	
6P	130	122	

KY-AN3300
3P Middle Power Feed-in

0.21 kg / pc

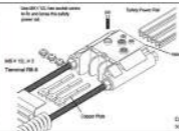

1. Insert safety power rail into the hole.
2. Use M10 x 12, hex socket screw to fix and tension the safety power rail (only two and half cycle needed when screw meet the safety power rail).
3. Power lines fixed with terminals, and tension the copper power plate.

Power rail PVC ped front

KY-AN3200N
3P End Tension & Power in

1.5 kg / pc

4P Safety power rail

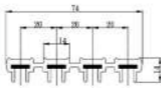

DFC 5N (99.9% good conductivity)

4P (Phase) Safety Power Rail				
Type	Capacity (A)	Thickness (mm)	Width (mm)	Weight (Kg/m)
KY-AN1007	75	2	10	1.1
KY-AN4010	100	2.8	10	1.4

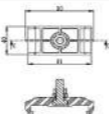

Use with C Track Support and C Plate M10 Nut 30x20x2"



KY-AN4100

4P Hanger Clamp

0.083 kg / pc

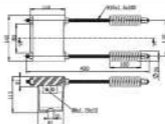

KY-AN4200

End Tension & Power in

1.74 kg / pc

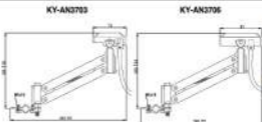

KY-AN3703

30A Current Collector

0.24 kg / pc

KY-AN3706

60A Current Collector

0.27 kg / pc

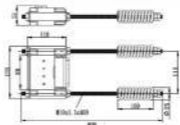

Power rail PVC post fixed

KY-AN4200N

End Tension & Power in

1.28 kg / pc

5P Safety power rail

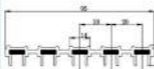

OFC 2N(99.9% good conductivity)
Conductor Cross Section: $2.81 \times 10 = 28.1 \text{mm}^2$

5P (Phase) Safety Power Rail				
Type	Capacity (A)	Thickness (mm)	Width (mm)	Weight (kg/m)
KY-AN5030	100	2.8	10	1.7

5P power rails use the same middle tension as 6P.

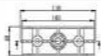

Use with C Track Support
and C Plate (Max) Size
 $30 \times 20 \times 0.5$

KY-AN5100
Hanger Clamp

0.09 kg / pc

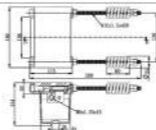

KY-AN5200

5P Middle Tension
& Power in

1.75 kg / pc

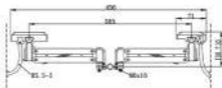

Made to Order

Twin Current
Collector

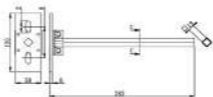

KY-AN3800

Fix Square Bar

0.7 kg / pc

6P Safety power rail

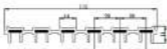

OFC (W) (99.9%, good conductivity)

6P (Phase) Safety Power Rail				
Type	Capacity (A)	Thickness (mm)	Width (mm)	Weight (kg/m)
KY-AN6007	75	2	10	1.64
KY-AN6010	100	2.8	10	2.06



Use with C-Track Support
and C-Plain-M10 Nut
30 X 30 X 5



KY-AN6100

6P Hanger Clamp

0.1 kg / pc

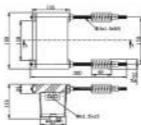

KY-AN6200

6P End Tension &
Power In

1.9 kg / pc

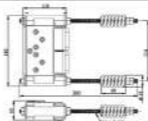

Power rail: PVC proof free!

KY-AN6200N

6P End Tension &
Power In

1.9 kg / pc

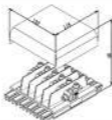

KY-AN6300

6P Middle Tension
& Power In

0.38 kg / pc

3P 200A Parts Diagram

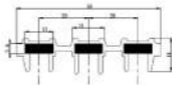

OFC 3N (99.9% pure conductivity)
Conductor Cross Section: 3.0" (114)=41.5mm²

3P(Phase) Safety Power Rail		
Type	Standard	kg/m
KY-AN3020	200 Amp	1.42

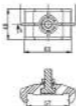

Use with C Track Support
and C Pole M10 Nut
30 X 20 X 2"



KY-AN3120	
3P Hanger Clamp	
0.075 kg / pc	

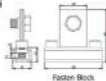
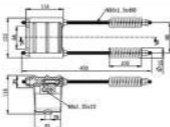

KY-AN3220	
3P End Tension & Power in	
1.75 kg / pc	

KYEC Safety Power Rail Test Result

Test Type	Material	Resistance coefficient (R/M)	Duration Potential	Decay of Potential(Δ/M)	200W/100h Decay Percentage	Temperature
W type 800A	Aluminum	0.000190	8KV X 30min	0.99	3.9%	23
W type 500A	Aluminum	0.000107	8KV X 30min	0.94	3.9%	23
W type 320A	Aluminum & Copper	0.000184	8KV X 30min	0.99	2.7%	23
3P 100A	Copper	0.000630	8KV X 30min	0.97	2.9%	23
3P 100A	Copper & Stainless Steel	0.000612	8KV X 30min	0.97	2.1%	23
3P 15A	Copper	0.000662	8KV X 30min	0.96	3.9%	23

Asay Institute : Industrial Technology Research Institute

Asay Instrument: **Brand & Model :** EST 242D
KIKUSUI TOS-8700
TAMA-TDY-20ADS **Name of instrument :**
PRECISION RES-MEASUREMENT SYSTEM
WITH RING VOLTAGE TESTER
HIGH VOLTAGE DIGITAL METER

3P 100A (Copper)

Length(M)	10	20	30	40	50	60	70	80	90	100
Decay of Potential(Δ)	0.87	1.14	1.71	2.28	2.85	3.42	3.99	4.56	5.13	5.70

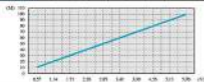

3P 100A (Stainless Steel)

Length(M)	10	20	30	40	50	60	70	80	90	100
Decay of Potential(Δ)	2.47	3.04	3.61	4.18	4.75	5.32	5.89	6.46	7.03	7.60

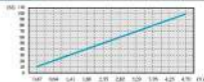

4P 200A Parts Diagram

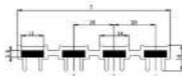

CPC 3N (99.9%, good conductivity)
Conductor Cross Section: 3.8*11mm² (6mm²)

4P(Phase)Safety Power Rail		
Type	Standard	kg/m
KY-AN4020	200 Amp	1.9

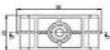

Use with C Track Support
and C Rail M10 Nut
30 X 20 X 2

KY-AN4120	
4P Hanger Clamp	
0.083 kg / pc	

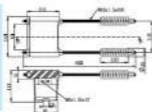

KY-AN4220	
4P End Tension & Power In	
1.75 kg / pc	

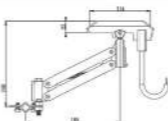

KY-AN3710	
N Current Collector 100A	
0.36 kg / pc	



KY-AN4300	
4P Middle Tension & Power In	
0.34 kg / pc	



⊗ Coupling with current collector
with power supply, it can clean
power rails in movement.

Clean Brush
Produce
on Demand

High Temperature Durable Box Safety Power Rail



KY-D3003 (6133)
ND3P Straight
Line Duct
3 kg / M



KY-D3702 (6175)
ND3P Trolley
20A
0.7 kg / pc

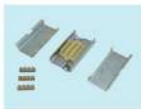

KY-D3500 (81331)
ND3P Coupling
Plate
0.3 kg / pc

KY-D3704 (6276)
ND3P Trolley
40A
0.8 kg / pc



KY-D3100 (6111)
ND3P Hanger
0.3 kg / pc

KY-D3600 (6117)
ND3P Trolley-
Pulling Bracket



KY-D3201 (6112)
ND3P End Cap
0.4 kg / pc

KY-D3001 (6001)
ND3P Trolley Collectors
KY-D3902 (6102)
ND3P Trolley Collectors 20A
KY-D3904 (6104)
ND3P Trolley Collectors 40A

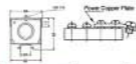

KY-D3200 (6173)
ND3P Feed-in
Box
1.2 kg / pc

Produce on Demand
Curved Duct



3P、4P、5P、6P Installments Diagram

Step 1 Support Design

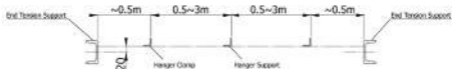

Remark

- (1) The side design installment recommended when a corner occurs to the 3-6P safety power rail assembly.
- (2) The hanger clamps are supposed to be installed every 0.5 meter from the starting point of the wiring.
- (3) The 3-6P tension part for safety power rails must be installed at the place about 10mm higher than the hanger clamp.

This step prevents water from flowing to the power-in place along the safety power rails, hence the short circuit won't happen.

- (4) The silica gel must be coated on the connected place of the power-in part and safety power rail as weather protection.
- (5) The 3-6P safety power rails are not suitable for outdoor usage or the place with high oxidizable environments.

Step 2 End tension & Power-in

Remark: (1) Install one end on the ground then lift rail up to estimated location and install another.

Step 3 Hanger clamp

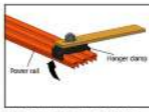
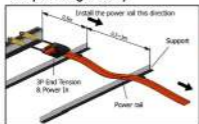

(1) Attach the hanger clamp with power rail and push up.

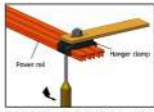

(2) Use a slotted screwdriver to disassemble the hanger clamp.

Step 4 End tension & Power-in

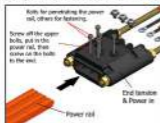

4-1

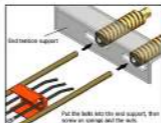

4-2

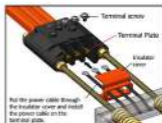

4-3

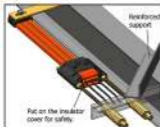

4-4

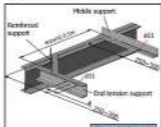

4-5

Terminal Plate Length	A
3P	90
4P	130
5P	130
6P	150
7P	170

- To avoid short circuit, please fasten the terminal plate with M8 x 16mm socket screws.

// Specifications are subject to change without notice.



Step 5 Fix square bar/current collector

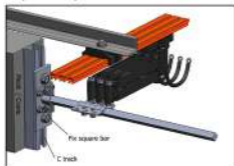

Remark:

- (1) Fix square bar could be welded on the crane or screw used.
- (2) Fix square bar's angle is supposed to be mounted. One diagonal of the bar must be parallel to ground and safety power rail, another is vertical.
- (3) Length could be cut as demand.
- (4) If carbon brushes worn, just replace a new one.

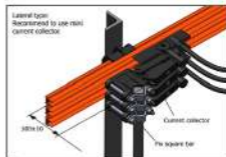
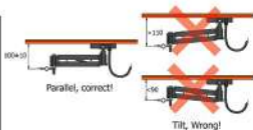

QUESTIONNAIRE

Please fill out the form. For curve tracks, we require drafts to prepare a quotation.

Company: _____ Tel: _____ Fax: _____

E-Mail: _____

- Number of power rail installations: _____
- Type of equipment to be powered: _____
- Voltage: _____ V, Phases: _____, Frequency: _____ Hz AC DC
- Track length: _____ m ; travel speed: _____ m/min. Indoor Outdoor plant
- Number of power rails: _____ (main rails: _____ control rails: _____ ground rail: _____)
- Type of power rail Combine (3P-6P power rail) Power rail respectively (I type)
- Other operating conditions (humidity, dust, chemical influence etc.) _____
- Ambient temperature: _____ °C min. _____ °C max.
- How are the rails laid out? (Please provide draft): _____
- Power consumption of the individual consumer loads: _____ (consult page 2)
- Max. voltage drop from the power rail feed to the consumer unit _____
- Remarks: _____

3P Rail connector and middle power in

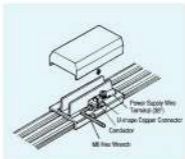

- (1) Cut off the PVC material at 30mm from the end of safety power rail.
- (2) Bend upward copper material in vertical 90° angle.
- (3) Insert both sides of 90° vertical angle safety power rail into middle power feeding and connect both sides by screwing up M8 inner hexagon screw bolt on U-type copper connector.

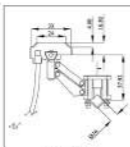

KY-AN37033

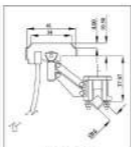

KY-AN37066



Mini Current Collector		
Type	Standard	kg/pc
KY-AN37033	30 Amp	0.14
KY-AN37066	60 Amp	0.17
KY-AN37101	100 Amp	0.27

Double set is available as photo, type for example is KY-AN37033D.

Current Collector Unit

Transit & Test System



DH-6832



DH-6813

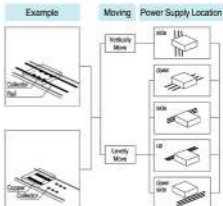
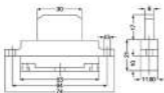

I type safety power rail instalment diagram

- Vertical instalment
- On Side Instalment
- Vertical Instalment Double
- Above Instalment Guide

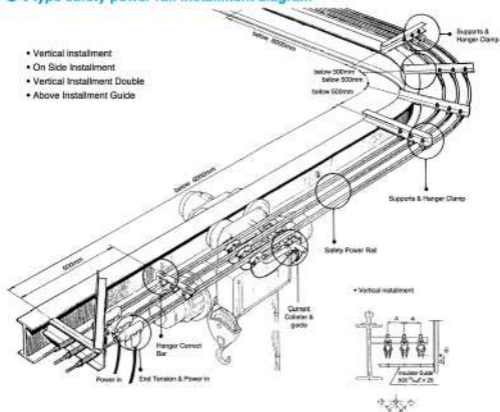

• On Side Instalment



• Vertical Instalment Double

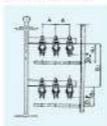

• Above Instalment

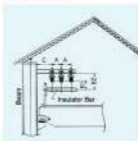

A	minimum	75
	standard	100

B	B 1	95
	B 2	130
	B 3	290

C	minimum	150
	standard	200

I type safety power rail Parts Diagram



OFC 3H 35/020, good conductivity

KY-AN1015

"I" Type Rail

0.47 kg / M

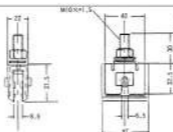

KY-AN1100

**"T" Type
Hanger Clamp**

0.11 kg / pc

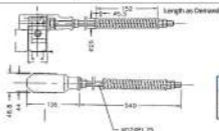

KY-AN1200

**"T" Type End
Tension & Power in**

1.1 kg / pc

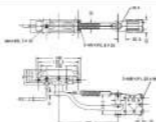

•100Amp

•40Amp

Carbon brush

KY-AN1704

KY-AN1710

**40/100 Amp
Current Collector**

0.83 kg / pc

1.17 kg / pc



KY-AN1838 380L

KY-AN1850 500L

Insulator Guide

1.45 kg / pc

1.82 kg / pc

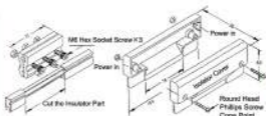

KY-AN1300

**"I" Type Middle
power feed in**

0.26 kg / pc

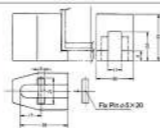

KY-AN1600

Fixed end insulator

0.07 kg / pc

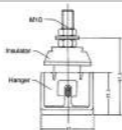

KY-AN1100S

**"I" Type
Insulator hanger**

0.15 kg / pc

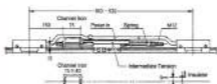

Produce on Demand

**Intermediate
tension insulator**

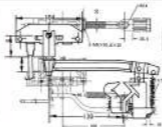

+100Amp

+40Amp

Carbon brush

KY-AXE0804

KY-AXE0810

**40/100 Amp
Current Collector**

**For ~8" type
power rail**

A = Aluminum body

I type safety power rail installation diagram

Step 1 Support Design

A. installation for I type in 30 meters



B. installation for I type over 30 meters

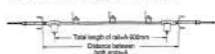

Line Case

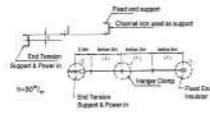

Curve Case

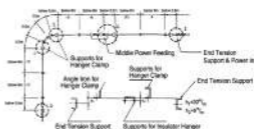

Around type

End Tension Support

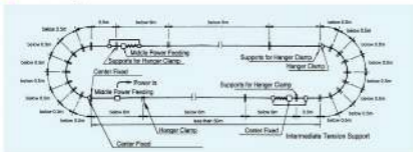

"S" type

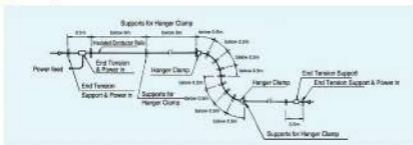

Around & Relief type

1. Distance of each hanger clamp must be under 0.5m in around type.
2. The way to pull up rail is use traverse table put on the saddle's beam, pull up the rail when crane moves. (As the commentary picture no.3 shown in end cover)

Step 2 Length in 30M

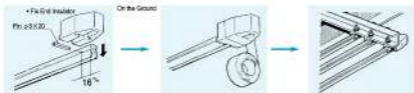

Length over 30M

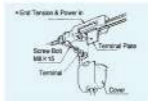

Step 3 Set & Hanger Clamp



• Use tool to slip Inward Plastic Clip and pull I-Type Insulated Conductor Rails set together if necessary.

Middle power feed in



- (1) Cut off 80mm long of insulated material PVC in the middle of I-Type Insulated Conductor Rails for supplying power.
- (2) Contact Copper Conductor of I-Type Insulated Conductor Rails by two piece of Copper Plate and fix it by M8 inner hexagon screw bolt.
- (3) Drill two holes $\phi 5$ mm through both Copper Plate and Copper conductor of I-Type Insulated Conductor Rails at the bottom and insert pins to connect and fix them.

Step 4 Set, End Tension & Power in

Step 5 Set, guide & Current Collector

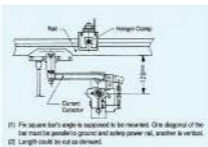
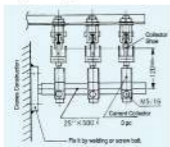

* Caution



- (1) It is not allowed to incline over 15° when install I-Type Insulated Conductor Rails.
- (2) If I-Type Insulated Conductor Rails still incline after installation, then it is required to adjust torquely.

Commentary

- | | | |
|-------------------------|---------------------------|---------------------|
| ① Current Collector Set | ③ Around Set | ⑤ Amusement Grounds |
| ② For Hoist | ④ For Hoist (Curve Track) | ⑥ Warehouse |

KYEC

 Kunyee Industrial Ltd.
<http://www.kyec-mit.com.tw>
 email : taiwan.kyec@mss.hinet.net

Head Office	TEL: +886-2-3207-888	FAX: +886-2-2296-770
Taipei Branch	TEL: +886-2-2294-8345	FAX: +886-2-2296-8848
Taiyang Branch	TEL: +886-4-2258-8875	FAX: +886-4-2258-2648
Kaohsiung Branch	TEL: +886-7-384-5997	FAX: +886-7-383-8729